

# COLUMN FLOTATION

GLENN DOBBY — SGS

## ABSTRACT

Industrial application of column flotation began in earnest in the early 1980's, and is now accepted as a conventional application. For example, most of the world's major copper producers use column flotation as the final stage of cleaning. In addition, the technology is common for final cleaning of zinc, lead and molybdenum sulfides, and for processing of iron ores and phosphates. This article includes a description of the key features and concepts of column flotation, and then reviews recent industrial applications of column flotation, covering pilot testing and scale-up, circuit design of selected applications, and instrumentation and control.

## INTRODUCTION

The invention of the flotation column by Pierre Boutin and Remi Tremblay (patented in 1962) came about from earlier work conducted on solvent extraction at the research laboratory of Eldorado Mining, in which they applied the column as it is known today to solvent-in-pulp processing of uranium ore. Slurried ore was fed near the top of a laboratory column and solvent droplets were generated at the bottom of the column. The density difference caused a counter-current flow of solvent droplets and slurry, and a solvent phase was created at the top of the column, with a distinct solvent-pulp interface. An aqueous diluent was introduced near the interface in order to minimize contamination of the solvent with ore particles. Slurry was drawn out the bottom of the column and solvent overflowed the top lip. (Boutin 2002)

Boutin and Tremblay then applied the concept to ore flotation, replacing the solvent droplets with air bubbles and replacing the diluent with water. The first successful applications were on amine flotation of silica from iron ore samples. The first notable industrial success of flotation columns was by Column Flotation Company of Canada on moly cleaning at Noranda's Les Mines Gaspé (Cienski and Coffin, 1981; Coffin and Mischczak, 1982).

Today column flotation has become an accepted means of froth flotation for a fairly broad range of applications, in particular the cleaning of sulfides (copper, zinc, lead and molybdenite) and the flotation of iron ore, phosphate and coal.

Flotation columns differ dramatically from mechanical flotation machines in several ways:

- there is no mechanical agitation/shear
- the cell is relatively tall and narrow
- gas bubbles are generated by sparging
- froths typically are deeper, and wash water typically is liberally applied to the surface of the froth.

There has been a wealth of research and fundamental studies on aspects of column flotation during the past 15 years or so (some of which has been described by Finch and Dobby, 1990 and by Finch, Uribe-Salas and Xu, 1994.). However, the fundamental aspects is not the focus here; rather, this article will review recent industrial applications of column flotation, covering pilot testing and scale-up, circuit design of selected applications, and instrumentation and control. We begin with a description of the key features and concepts of column flotation.

## KEY FEATURES AND CONCEPTS

A schematic of a flotation column is shown in Figure 1.

Industrial flotation columns are 6-14 m in height (from the bottom discharge to the top lip), and range in diameter from 0.5 to 5 m. Recent large scale applications have typically been 4 to 4.5 m diameter and approximately 12 m tall. [There are many installations of columns that are rectangular. The fabrication cost for rectangular columns is significantly higher than for circular columns, as approximately twice the mass of steel is required; however, there is no evidence that rectangular columns will provide better metallurgy than from circular columns.]

As with mechanical cells, two distinct zones are evident: the collection zone (extending from the spargers to the froth:pulp interface) and the froth zone. Interaction between these two zones, especially the recycle of collected particles from the froth to the pulp, is particularly important in understanding design and operation of a flotation column; this is addressed in the Scale-up section.

The froth of a flotation column is usually water washed, with approximately as much wash water as there is water reporting to the froth. The water is most commonly added via pans, perforated with 4-8 mm diameter holes, located 20-30 cm above the froth, thus generating a "rain" of water onto the surface of the froth.

The key objective of water washing the froth is to minimize recovery of hydrophilic gangue particles into the concentrate via hydraulic entrainment; the wash water replaces feed water that would have otherwise reported to the concentrate, carrying gangue particles with it. The effect of the water addition is to create a froth where the gas bubbles do not coalesce to the same degree as in non-water washed froths (Yianatos, Finch and Laplante, 1986 and 1987). Hence, a column froth is usually very stable even when deep; an industrial column froth is typically 0.6-1.0 m deep.

The wash water stream/droplets must be large enough to penetrate the top layer of the froth, because the washing action takes place primarily at the froth/pulp interface (Yianatos, Finch and Laplante, 1987). If the water stream is too light then there will be a tendency for the water to simply bypass the froth directly into the concentrate. For heavy froths, some operators implement wash water delivery via perforated pipes immersed several centimeters below the top of the froth.

Some key terminology and concepts follows.

**Superficial velocity** Phase flowrates can be expressed as a superficial velocity by dividing the flowrate by the column cross-sectional area. Hence, gas flowrate is often expressed as a gas velocity  $J_g$ , with usual units of cm/s. The range of  $J_g$  observed in industrial flotation columns is typically between 1 and 2 cm/s (this is the flowrate at the top of the column; a static head of typically 1 atm means that the true gas rate at the bottom of the column is about half that at the top.). Likewise, feed rate of slurry can be expressed as a velocity.

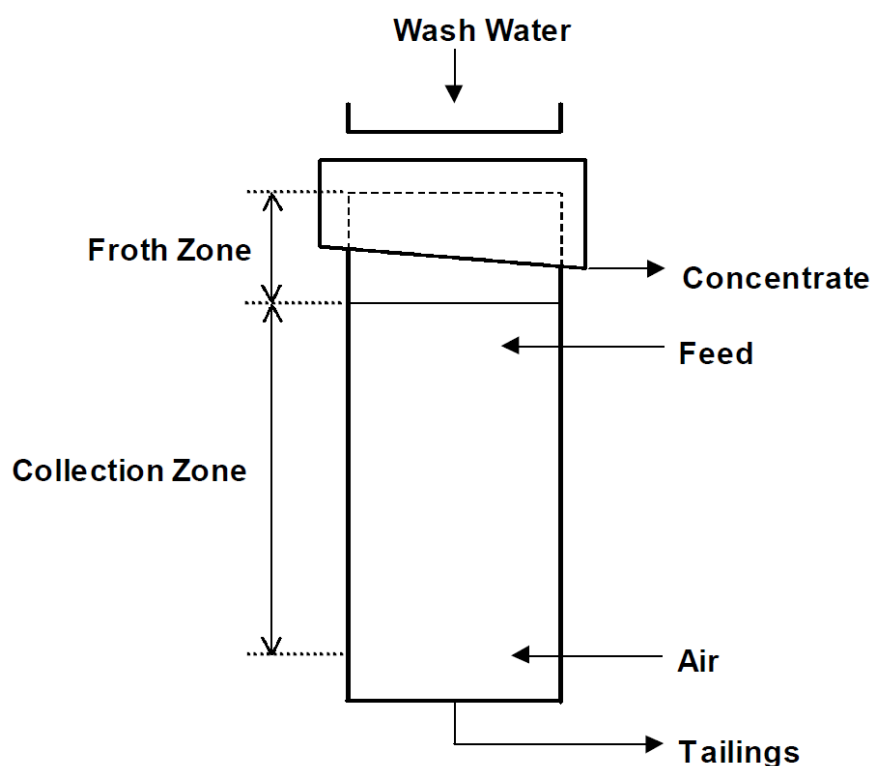

Figure 1 Schematic drawing of a flotation column.

**Bias** The difference between wash water flow rate and concentrate water flow rate is referred to as the "bias". When wash water flow exceeds concentrate water flow, the bias is positive; the bias is negative when the reverse occurs. A zero bias means that the two flows are the same; as stated earlier, a common approach with column flotation is to operate in the range of a zero bias, perhaps a bit higher or a bit lower. As with other flows, bias can be expressed as a superficial velocity,  $J_b$  (again, expressed in cm/s).

Another method to describe the relationship between wash water flow and concentrate water flow is to quantify the wash water in terms of displacement washes. One displacement wash means that the wash water flow equals the concentrate water flow (one displacement wash is the same as a zero bias).

#### Carrying Rate and Carrying Capacity

The available surface area of a flotation machine is an important consideration in most cleaning circuits and, because of its small diameter:height ratio, it is particularly so with flotation columns. The concentrate solids flux is referred to

as the carrying rate  $C_a$ , described in units of tph/m<sup>2</sup>. Industrial columns typically operate at between 1 and 3 tph/m<sup>2</sup>, depending on the level of wash water addition and the particle size of the concentrate (smaller particles will result in lower carrying rates). The maximum carrying rate is referred to as the carrying capacity  $C_M$ . Effects of particle size and water addition on carrying rate and carrying capacity are discussed further in the following section.

**Gas Holdup and Bubble Size** The volume of the collection zone occupied by gas bubbles, referred to as the gas holdup and expressed as a percentage, can be used as a diagnostic feature. This is because the gas holdup is a function of both gas rate and bubble size; hence, knowing the gas rate and the gas holdup can lead to an inferred calculation of average bubble size. Bubble size, as with other flotation machines, clearly plays an important role in column operation. Smaller gas bubbles are generally preferred. However, in primary cleaning of mineral systems with high kinetics, very small gas bubbles will tend to hurt froth mobility, and hence are undesirable.

Bubble generation in flotation columns was originally achieved via sparging through pierced rubber or through woven fabric. That approach is no longer very common, as the column must be shut down and drained to assess or replace sparger units. Today there are two principle bubble generation technologies.

The most common method of bubble generation is jet sparging of air through orifices. Air is forced under high pressure (30-100 psig) through annular or circular orifices, creating a jet of air through the slurry. The high shear that exists at the gas-slurry interface results in generation of gas bubbles. Bubble diameter is affected by the jet velocity; the higher the jet velocity the smaller the resulting bubbles. The spargers are fit into the column through a nipple and valve assembly, extending only several centimeters into the pulp. With this configuration, the spargers can be removed and inserted while the column is full of slurry and under operation. A large column will use 15-20 spargers.

The second principle method of bubble generation employed today is through pumping of a portion of the underflow through static mixers back into the pulp, employed by the Microcel technology (Yoon and Luttrell, 1994). Air is injected at the static mixer, and the resultant high shear through the mixer generates very small gas bubbles; hence, the bubble generation is external to the column. A typical column will have several static mixers fed by a common pump and header.

An advantage of the static mixer approach is that it can produce smaller gas bubbles. However, this is at the expense of pumping a very high slurry flow through the mixers. The Microcel approach has been applied primarily to coal flotation, with a large and successful installation at BHP Coal's Peak Downs coal preparation plant (Brake, 1998).

Whatever method of air addition employed, the pressure drop of a column will require that the air is supplied via a compressor (not a blower). Selection of the correct compressor capacity clearly is important.

## PILOT TESTING AND SCALE-UP

Metallurgical testing of column flotation has generally been through continuous pilot plant operation. For retrofitting at existing plants, the approach has been to conduct pilot testing on site, feeding a bleed stream from the plant circuit to the pilot plant circuit (Kosick et. al. 1991). Typical pilot columns are 10 cm diameter by 6 m tall, although pilot testing has been conducted with columns as small as 5 cm and as large as 30 cm. There have been some attempts to conduct pilot testing and scale-up through operation of a batch laboratory column (Flint, 2002).

Since the mechanism of particle capture differs significantly between a mechanical cell and a flotation column, kinetic data obtained from bench mechanical flotation machines generally is not easily applied to column sizing. This sometimes poses a problem for design and sizing of columns for cleaning on green-fields design. The quantity of rougher feed required to generate sufficient rougher concentrate for column pilot testing is generally too large to justify a pilot plant. However, the selectivity that is obtained from the bench testing can be used for helping design the number of stages of cleaning. New tools have been developed to assist in the design of circuits using flotation columns (Dobby et al. 2002), and the design of sulfide cleaner circuits for greenfield plants is entirely feasible without the need for pilot testing (aside from some uncommonly complex ores).

Scale-up of flotation columns has been well documented (Finch and Dobby, 1990). The general approach is to apply a first-order kinetic model to particle collection, and select froth zone recoveries appropriate for the size of the columns and the froth mobility. Particle retention time may be significantly different from that of the water, especially for coarse particles, so the retention time of particles needs to be calculated and applied. Hydraulic entrainment of fine particles is accounted for by quantifying the recovery of water to the froth; for columns operating with a bias close to zero, the effect of entrainment is usually minor.

A key factor in column design is the froth recovery, which directly controls the extent of re-circulation within the column. As a general observation, the froth recovery of pilot columns is considerably higher than in large industrial columns, due to the stability imparted to the froth by the walls in a pilot column.

Therefore, in sizing large columns from pilot plant data the designed retention time will be longer for two reasons:

- a) short-circuiting Since the large column has a fluid flow pattern that is closer to a stirred tank than a plug flow vessel (opposite to that of a pilot column), a longer retention time is required to achieve the same collection zone recovery as in the pilot column
- b) lower froth recovery Since the plant column will have a lower froth recovery (i.e. higher internal circulating load) it is necessary to have a higher collection zone recovery than the pilot column in order to attain the same overall column recovery as with the pilot column.

Three issues deserve further elaboration: carrying capacity, required bias flow and column height.

**Carrying Capacity** Operation of full scale columns has shown that carrying capacity ( $C_M$ ) for a large column can be substantially lower than that of a pilot column. For example, Espinosa and Johnson (1991) reported a  $C_M$  for 2 m and 2.5 m diameter plant columns on lead and zinc cleaning that was about 50% of the  $C_M$  for a 5 cm pilot column. However, the trend of higher carrying capacity for higher  $k_{80}$  is still valid for plant columns.

An important and often neglected issue when quoting  $C_M$ , whether for a pilot column or a full scale column, is the value for the operating bias. Figure 2 is an example of measured concentrate solids flux  $C_a$  for a copper cleaning pilot column, plotted as a function of bias. In this case feed grade to the column is high, so  $C_a$  is reasonably close to  $C_M$  and  $C_M$  would be expected to follow the same trend as in Figure 2. A full scale column circuit was installed subsequent

to the pilot column work, and the plant operating region for a 3.0 m diameter column is also shown in Figure 2; it is at a significantly lower level than that obtained in the pilot column operation and is in reasonably good agreement with the observation reported by Espinosa and Johnson (note that the plant columns did use internal launders in addition to the external launder).

**Required Bias** Flow Figure 2 clearly indicates that carrying capacity will increase as operating bias is decreased. Bias can be decreased by decreasing the wash water rate or by increasing the gas rate. An example of the latter is shown in Figure 3, which was obtained from column cleaning on copper rougher concentrate with a 10 cm diameter pilot column, upgrading from about 14 %Cu to 34 %Cu. The data in Figure 3 was derived with two sparger fabrics, with Fabric 2 being considerably more permeable than Fabric 1 and thereby generating larger gas bubbles than Fabric 1 (the generation of larger gas bubbles could be inferred from gas holdup measurements that were made for each test). The bias is expected to decrease when smaller gas bubbles are generated (and gas rate remains the same) because the larger interfacial area will carry more water from the collection zone into the froth zone.

It has been demonstrated several times (e.g. Furey, 1990, Espinosa and Johnson, 1991) that operation of a column at zero to slightly positive bias will usually maximize the concentrate grade. A further increase in bias, through wash water addition, to a point significantly above a zero bias will generally result in minimal grade increase but a substantial recovery loss. An example of this is shown in Figure 4, for copper cleaning in a 10 cm diameter pilot column.

In general, a good guideline is to provide sufficient wash water such that the column operates at close to zero bias. More definitive guidelines for a given installation must take into account the operating grade-recovery curve and economic efficiencies specific to that operation; in some cases it will be more profitable to run with a slightly negative bias. Such a situation arises when the

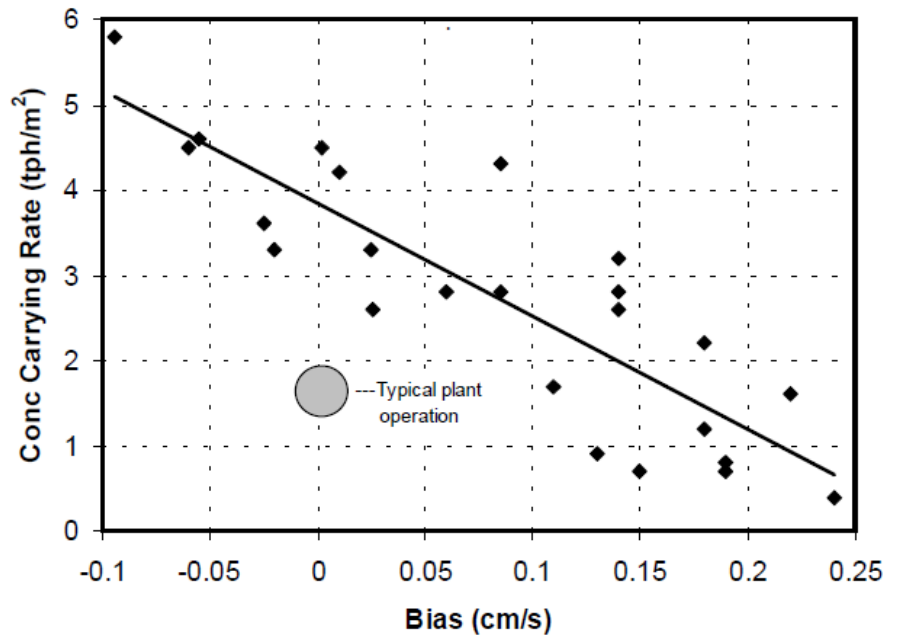

Figure 2 Concentrate solids carrying rate versus bias with a pilot column used for copper cleaning, and for the resulting plant column operation (Dobby and Kosick, 1995).

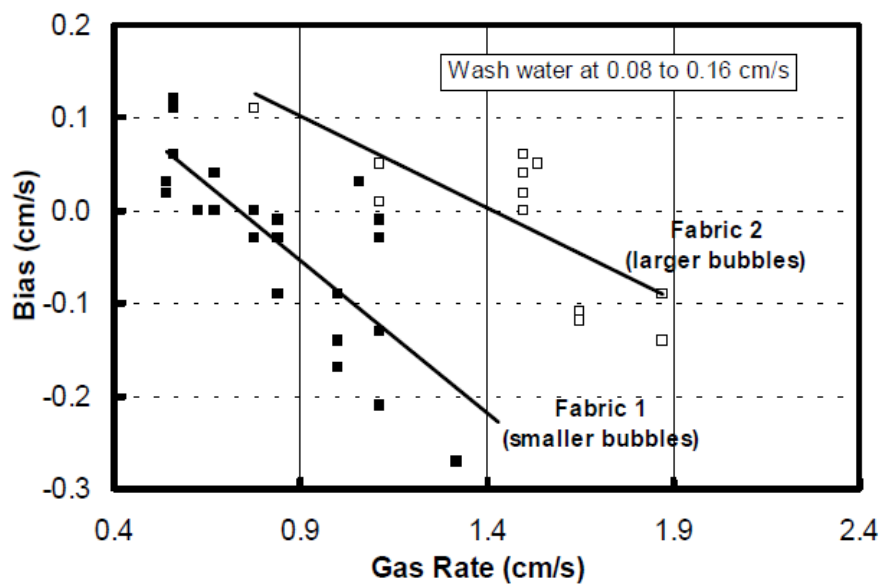

Figure 3 Effect of gas rate and bubble size on bias in a pilot column.

column circuit must temporarily process high grade feed. As another example, if insufficient column capacity has been installed, it will be difficult to operate the columns with a positive bias while still attaining target recovery.

**Column height** The height of a flotation column is generally determined by required retention time, accounting for both short-circuiting and a significant degree of froth dropback. That being said, it has been reasonably common to adjust the designed column height slightly to better fit within a plant layout.

There are situations where tall columns are undesirable. This arises when the feed grade is high and the floatable mineral has very fast flotation kinetics, which will cause the froth to become fully loaded with solids with a short retention time. Any further retention time, i.e. more collection zone height, is ineffective, as the gas bubbles become fully loaded before reaching the froth-pulp interface.

An installation that takes advantage of this is the zinc cleaning circuit at the Doe Run Company's Fletcher concentrator

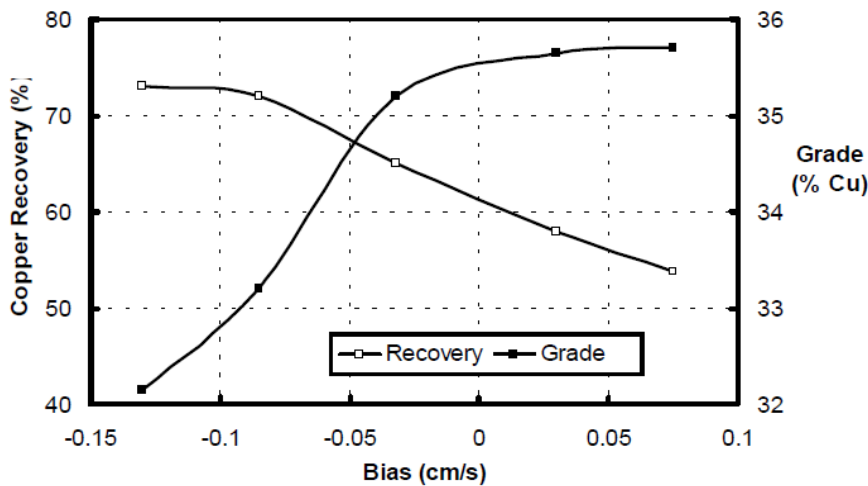

Figure 4 Example of the effect of bias on grade and recovery for copper cleaning in a pilot column.

in Missouri. The cleaner circuit consists of two columns in a counter-current cleaning configuration, with 1st cleaner tailings recycled to rougher feed. Rougher concentrate is typically 15% Zn and final concentrate is typically 60 %Zn. Both columns are 1.7 m diameter. The 1st cleaner column is 12 m tall (from floor to lip) and the 2nd cleaner column is 8 m tall. This allows gravity flow of 1st cleaner concentrate to the 2nd cleaner, via a head tank, and saves a pumping stage. The overflow of the 2nd cleaner column is setup at the same floor level as the existing mechanical cells.

Another installation that has successfully applied a combination of tall and short columns is the iron ore flotation plant at Samitri, Brazil (described further in the following section).

### CIRCUIT DESIGN AND APPLICATIONS

Most installations today use a combination of columns and mechanical cells within distinct circuits. This has arisen partially from the retrofit application of columns, where stages that produce an intermediate concentrate can be implemented with existing mechanical cell equipment. However, the application of columns together with mechanical cells has been driven primarily by the desire to match optimum cell properties to the duty required. This has resulted in the final stage(s) of cleaning by column flotation and cleaner scavenging in mechanical cells.

With the advent of flotation columns has come the option of arranging cleaning circuits in a scavenger configuration in addition to the conventional counter-current cleaning approach. The selection of cleaner circuit configuration in either a cleaner mode or a scavenger mode is determined from the level of upgrading required in conjunction with the selectivity of the particular process, and the total quantity of solids to be removed as froth product. In applications where there is a high level of solids recovery to the froth, there will be significant capital cost savings in being able to use a scavenger configuration, with which the solids are quickly removed from the circuit.

Further circuit design issues will be highlighted in the section as specific applications are described. Examples that follow are for sulfide cleaning, iron ore flotation and phosphate flotation

### EXAMPLES OF COPPER AND ZINC CLEANING

The most accepted application of column flotation is for final cleaning in copper sulfide flotation; a majority of large copper plants today utilize columns. Two of the most common cleaner circuit flowsheets are shown in Figures 5a and 5b. Both the Candelaria concentrator and the Collahuasi concentrator in Chile use 5a, while Antamina (in Peru) and Escondida Phase 3.5 (in Chile) employ the flowsheet in Figure 5b. The Antamina copper installation uses eight 4.3 m diameter columns, four for each stage, while Escondida has a total of 14 columns (usually 12 are in use), each 4 m square in cross-section.

For zinc cleaning, the column flowsheet employed depends on the rate of zinc flotation and the selectivity between sphalerite and the gangue minerals (usually pyrite). When the sphalerite flotation rate is fast, then a reasonably high stage recovery can be obtained in the first column, allowing the use of the flowsheet shown in Figure 5b. When the sphalerite is slower floating and selectivity is not high, as typically occurs with complex sulfides, then the stage

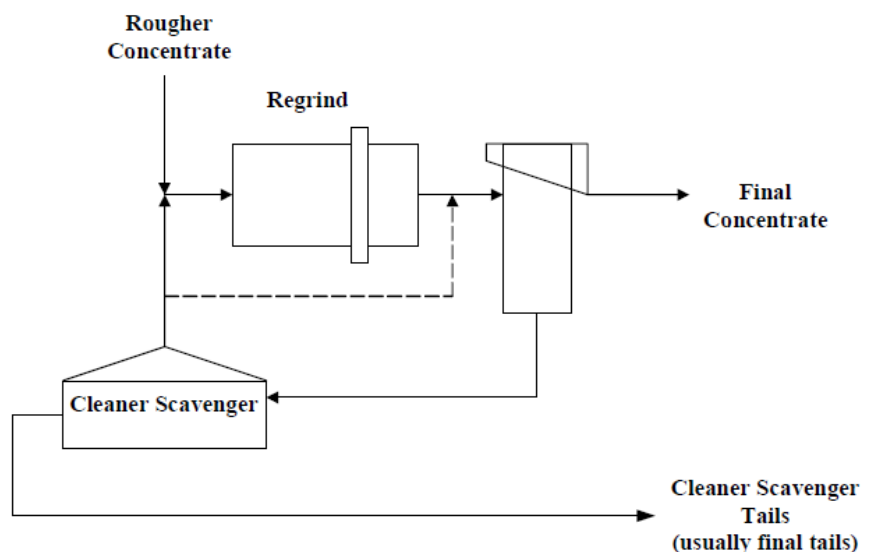

Figure 5a A simple column cleaning circuit, applied in several porphyry copper concentrators.

recovery of the first column is not very high and it is common to employ two stages of columns in series. Examples of this are from the Laronde Division of Agnico Eagle (Figure 6) and BHP-Billiton's Les Mines Selbaie (Figure 7).

For many column applications there is a choice between implementing either two or three stages of columns/mechanical cells. This is particularly so in copper and zinc cleaning. Using three stages will increase the overall project capital cost (though not necessarily proportionately) with the benefit of improved selectivity. A clear example of this is shown in Table 1, which summarizes results from pilot column cleaning on zinc 1st cleaner concentrate at Les Mines Selbaie in Canada, and compares results from the main plant mechanical cleaners, a CC/scavenger-open pilot column circuit and a CCC/scavenger-closed pilot column circuit. Both column circuits performed significantly better than the plant 2nd and 3rd cleaners (as would be expected, because the plant cleaners were undersized for the application). The three-column circuit produced a concentrate about 2 % higher in zinc than the two column circuit (even though feed grade was about 3% lower). The feed rate to both circuits was similar, so the three column circuit had a higher overall residence time. However, only part of the improvement of the CCC circuit over the CC circuit can be attributed to the increased residence time; a significant portion of the improvement was due to the better selectivity attained by increasing the number of circuit stages. A three stage (CCM/scavenger) circuit was installed at Selbaie, treating 1st cleaner concentrate (Chevalier and Dobby, 1996.).

[This example was from a complex sulfide application, where zinc flotation rate and selectivity were not high. A faster floating zinc ore with better selectivity may not see as significant a difference between two and three stages of cleaning.]

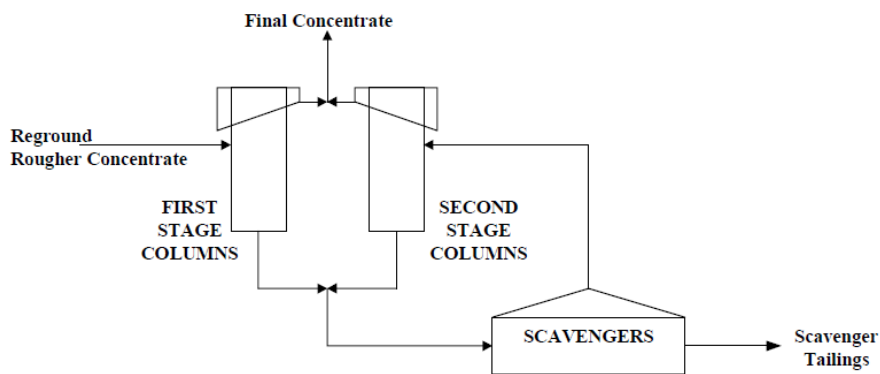

Figure 5b A three stage column-mechanical cell circuit applied on some copper and zinc ores.

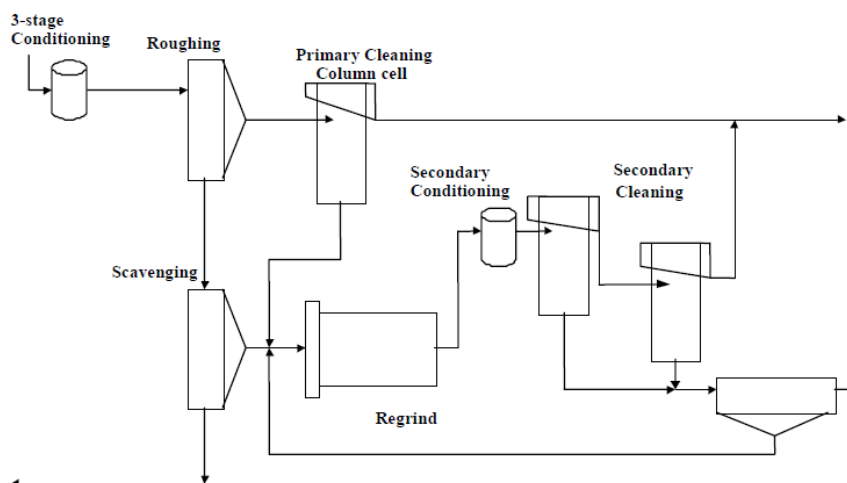

Figure 6 Zinc flotation circuit at Agnico Eagle's Laronde concentrator (Werniuk, 2000)

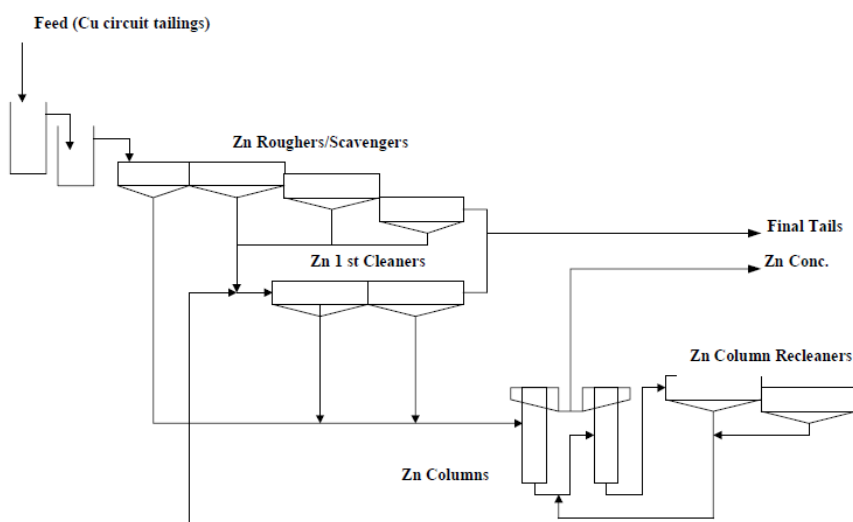

Figure 7 Zinc flotation circuit at the BHP-Billiton's Les Mines Selbaie (Wright, 1995).

Table 1 Example of column and plant performance in zinc cleaning, showing the difference between two stage and three stage column circuits.

Circuit	Feed Rate (L/min)	Feed %Zn	Conc %Zn	Zn Recovery
Plant mechanical cleaners		42.6	55.5	57
Two Columns	3.3	41.4	57.2	82
Three Columns	3.3	38.2	59.1	84

**MOLYBDENITE CLEANING**

As mentioned in the introduction, the first notable industrial application of column flotation was on molybdenite cleaning at Les Mines Gaspé, where three columns replaced approximately 10 stages of mechanical cells. Since then, column flotation has become the standard approach for molybdenite cleaning circuits. Typically threestsequential column stages conduct the final cleaning, treating either rougher concentrate or 1 cleaner concentrate generated in mechanical cells. An approach to determining the number of stages required has been described by Amelunxen (1990). At the Endako concentrator in British Columbia, Canada five columns are used, two at 2.7 m diameter, two at 1.5 m diameter and one at 1.1 m diameter, all 10 m tall.

An additional advantage of using columns for molybdenum cleaning from bulk copper-moly concentrate is that the columns are well suited to the use of nitrogen in place of air (which is sometimes practiced in order to significantly reduce the consumption of sodium hydrosulfide, used for copper sulfide depression).

**IRON ORE FLOTATION**

The selectivity of silica flotation from hematite can be extremely high, and pilot column flotation of silica has shown extremely impressive separation performance, especially on applications of Brazilian iron ore. This is because column wash water is very effective at rejecting from the froth the high level of hematite fines that occur in the feed.

However, there have been several failures in industrial applications, primarily due to errors in scale-up. Scale-up must be done with care, for two reasons:

- the target level of silica in the underflow is usually <1%, so when the feed grade is high (15-25 %silica) the recovery of silica to the froth product must be higher than 90 %, at which point short-circuiting of slurry in the collection zone plays a dramatic role; and
- as discussed earlier, the plant column will provide a considerably lower degree of stability to the froth, which means that there will much higher dropback from the froth to the pulp Hence, the increased short-circuiting that occurs in the industrial column and the significantly higher degree of internal circulation combine to prevent successful separation in one (or even two) column stages. In addition, the lower froth recovery in the industrial column is usually magnified for coarse silica, often resulting in difficulties with removal of coarse silica.

The solution to the problem described above is to use several stages of flotation. A good example of this is from CVRD’s Samitri circuit in Brazil, Figure 8. All of the four columns are 4.6 m diameter. The first (rougher) rougher and the cleaner-scavenger column are both water washed and only 8 m tall, while the cleaner and re-cleaner columns are not water washed and are 15 m tall. Froth from the two tall columns feeds the scavenger column by gravity flow. The feed grade to this circuit is typically 20 % silica or higher. Most of the silica is removed in the front end column circuit, and the mechanical secondary circuit ensures removal of coarse silica.

**PHOSPHATE FLOTATION**

Flotation columns have been applied successfully for phosphate flotation in both Brazil and Florida. A good example is the Serrana concentrator (Brazil), where six columns are in operation (Guimarães and Peres 2000, Guimarães et al. 1999). Each (rectangular) column is 3 m by 4.5 m by 14.5 m tall. Th3e columns were all installed as retrofits to the existing mechanical cells; ultimately 66 8.4 m cells were replaced by the six columns. The flowsheet for the plant is shown in Figure 9, and typical operating conditions for each column are summarized in Table 2.

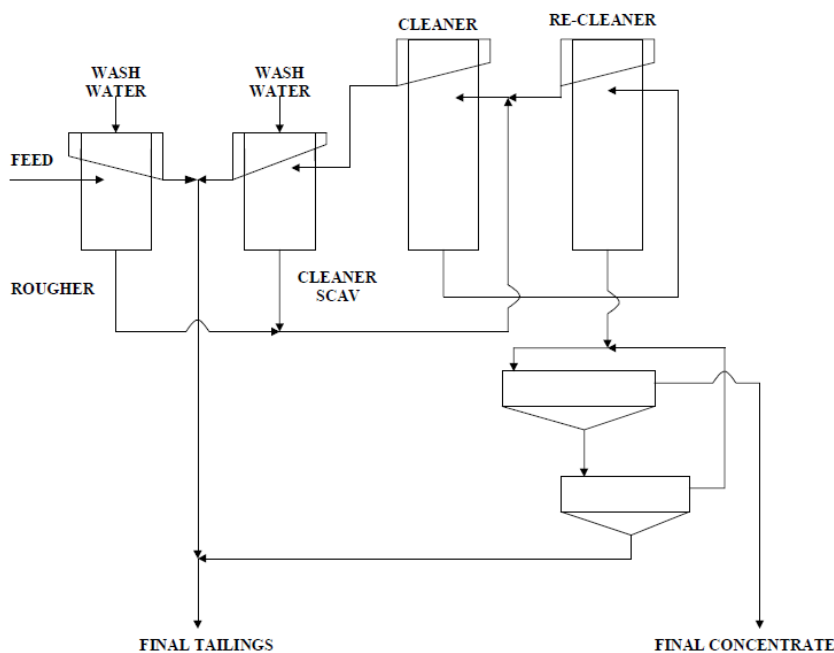

Figure 8 Flowsheet for silica flotation from iron ore at CVRD’s Samitri (Alegria) concentrator.

Table 2 Typical operating conditions for the phosphate flotation columns at Serrana (Guimarães et al. 1999)

ITEM	UNITS	APATITE: NATURAL FINES	APATITE: FINES FROM GRINDING	APATITE: COARSE	APATITE: REGROUND	BARITE; COARSE
Air	cm/s	0.9	0.9	0.97	0.82	0.94
Wash water	cm/s	0.19	0.19	0.19	0.23	0.13
Bias	cm/s	0.08	0.05	0.12	0.17	0.02
Residence Time	min	39	61	50	33	24
Carrying Rate	t/h/m <sup>2</sup>	1.5	1.7	2.7	1.2	1.4
Lip loading	kg/h/m	550	630	1000	440	510
Froth Depth	cm/s	70	70	60	60	25

## INSTRUMENTATION AND CONTROL

The degree of instrumentation on an industrial flotation column can range from very basic to reasonably complex. The minimum control requirement is that for pulp level. However, a typical industrial column will have automatic control of level, air flow rate and wash water flow.

The low ratio of surface area to volume inherent with a column means that the pulp level (which directly affects froth depth of course) will change quickly and significantly with changes in feed flow rate. Hence, this puts emphasis on good tuning of level controllers, but more importantly on ensuring that a reasonably stable feed flow is provided to the column. Feed to a column may be directly from a pump; however, multiple columns in parallel are usually fed via a slurry distributor.

Typically, pulp level sensing is through a float/plate assembly that acts as a target for an ultrasonic sensor. The level control element normally is a pinch valve, often raised a few meters from the bottom of the column in order to reduce pressure drop (and hence wear) across the valve. In some applications a variable speed pumps is used in place of the pinch valve.

Other sensors and control elements may include pressure sensors for detecting bulk density of the column, and automatic shutdown and startup knife-gate valves for slurry.

Various strategies exist for control of a flotation column. Level control, as stated earlier, is clearly the most important. There has been much discussion on control of bias; the difficulty with this is that an industrial sensor for bias is presently unavailable. In fact, for many applications the bias does not need to be controlled. Consider the following example from sulfide cleaning. Assume that wash water has been set for typical operating conditions to provide approximately a zero bias. When concentrate production will be higher because of higher feed grade, the bias will shift to negative; however, this is

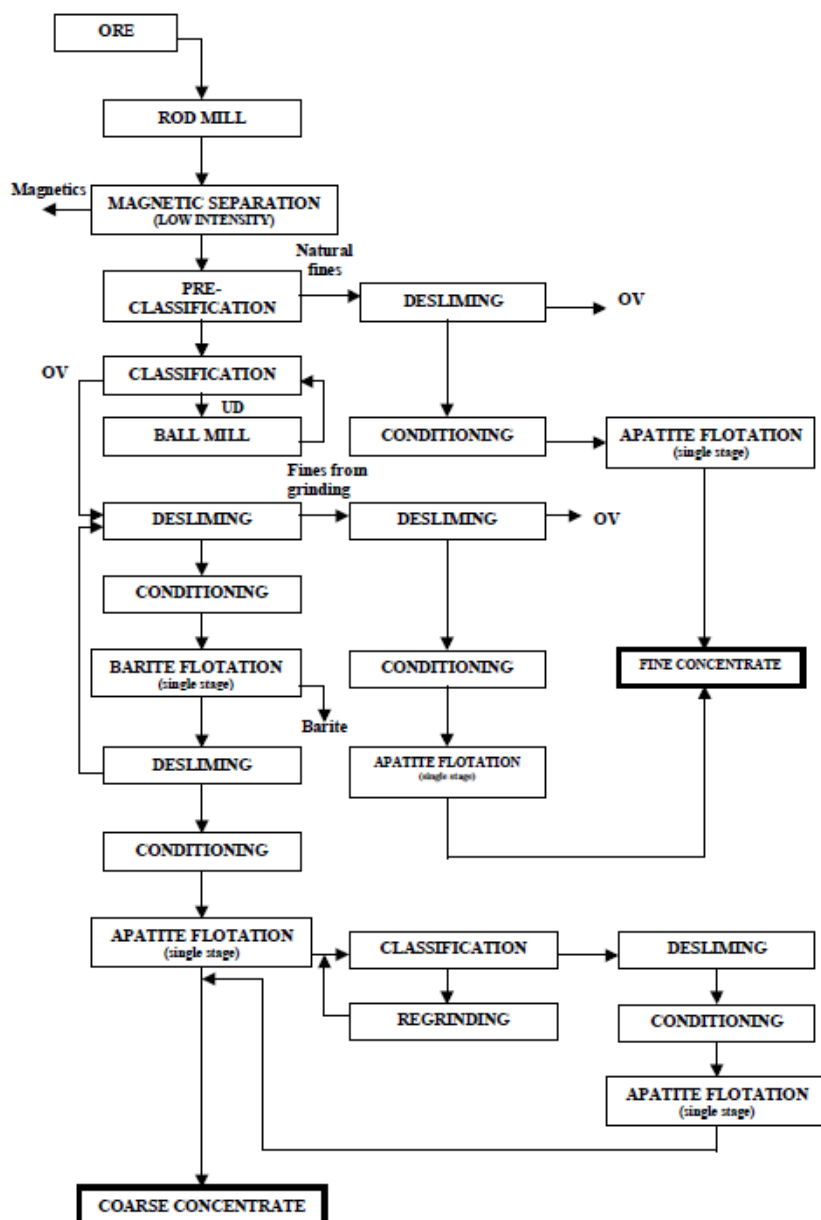

Figure 9 Flowsheet for phosphate flotation at the Araxá concentrator of Serrana (Guimarães et al, 1999).



probably where the operation should be in order to ensure good recovery across the column under conditions where concentrate grade should be less of an issue than recovery. And on the other hand, when concentrate production will be lower, the bias will shift to positive. Again, this is not necessarily bad, as there is more capacity available and the higher level of water washing will be beneficial.

Advanced control that manipulates wash water, air and level set points needs to be built into an overall circuit control strategy, which will be unique for each application.

## LIMITATIONS/CAUTIONS

Development of column flotation in the minerals industry has not been without its failures. There are several aspects of application and implementation which require particularly close attention, in either pilot testing or scale-up. Two of these follow.

**Feed conditioning** Some applications will require fairly intense feed conditioning and, unlike mechanical cells, a flotation column will provide very little conditioning. Hence, when conditioning is necessary it must be entirely complete before being fed to the column. If conditioning is applied in pilot testing then it must also be applied in the full design, to the same extent as used in the pilot testing. In some cases this is impractical, in which case the need for conditioning, and the degree of conditioning applied, needs to be closely evaluated at the pilot stage.

**Fine particle flotation** Depending on the nature of the surface chemicals employed, flotation of very fine particles in flotation columns often is not as effective as in mechanical cells. This could be related to poorer bubble collection efficiency for fine particles in the absence of high shear, or the need for "surface cleaning" of slimes via a high shear environment. The size at which performance deteriorates significantly is a function of the nature of the mineral system and surface chemicals employed, and must be determined through pilot testing.

## CONCLUDING COMMENTS

The engineering of flotation columns has advanced significantly over the past 20 years.

- Through the application of well defined scale-up methodologies, flotation columns can be reliably designed and sized.
- Sparger technology is reliable and robust.
- Methods for instrumenting and controlling columns are well defined and routinely implemented.

The next challenge will be advanced process control of flotation circuits employing flotation columns.

## ACKNOWLEDGEMENTS

The author would like to recognize efforts of the team responsible for development of flotation column technology at MinnovEX during the past 12 years, especially Glenn Kosick and Dale Coupland. In addition, support of staff from the many operating mines where MinnovEX has applied column flotation technology is gratefully acknowledged.

## REFERENCES

- Amelunxen, R.L. 1990. Moly upgrading profiles with flotation columns, CMP Proc. 22nd Annual Meeting, p.258
- Boutin, P. 2002. Private communication to the author
- Brake, I.R. 1998. The development and commissioning of a new Microcel column flotation circuit for BHP Coal's Peak Downs coal preparation plant, XIIIth Coal Preparation Congress, Brisbane, Australia
- Chevalier, G. and Dobby, G. 1996. Flotation column installations for zinc and copper cleaning at Les Mines Selbaie, at Copper '96, CIM Conf of Metallurgists, Montreal
- Ciensi, T. and Coffin, V.L. 1981. CMP Proc. 13th Annual Meeting, p.240
- Coffin, V.L. and Miszczak, J. 1982. Proc. 14th Int. Mineral Processing Congress, Toronto, paper 4- 21
- Dobby, G. and Kosick, G. 1995. Case studies on circuit design using flotation columns, CMP Proc. 27th Annual Meeting, p.171
- Dobby, G., Kosick, G. and Amelunxen, R. 2002. A focus on variability within the orebody for improved design of flotation plants, CMP Proc. 34th Annual Meeting, p.77
- Espinosa-Gomez, R. and Johnson, N.W. 1991. Technical experiences with conventional columns at Mount Isa Mines Limited, Proc. Column '91 (Agar, Huls and Hyma, eds.), Sudbury, CIM
- Flint, I. 2002. Batch flotation modeling, PhD thesis, UBC, Canada
- Finch, J.A. and Dobby, G.S. 1990. Column Flotation, Pergamon Press
- Finch, J.A., Uribe-Salas, A. and Xu, M. 1994. Column flotation: a selected review Part III, in "Flotation - Science and Engineering" (ed. K.A. Matis), Marcel Dekker
- Furey, J.T. 1990. Rougher column flotation of gold tellurides, CMP Proc. 22nd Annual Meeting
- Guimaraes, R.C., Takata, L.A., Peres, A.E.C. and Wyslouzil, H. 1999. Column flotation applied to the production of phosphate rock in Araxá, Brazil, Proc. 31st Annual Canadian Mineral Processors Operators Conf.
- Kosick, G., Dobby, G. and Shimizu, P. 1991. The use of column flotation pilot plants for column flotation circuit design, Proc. Column '91, Canadian Inst. Min. & Metall., Vol 2, p.359
- Werniuk, J. 2000. Getting down and dirty at Laronde, Canadian Mining J., August, p.13
- Wright, A. 1995. Flotation at Les Mines Selbaie, CMP Proc. 27th Annual Meeting, p.120
- Yianatos, J.B., Finch, J.A. and Laplante, A.R. 1986. Holdup profile and bubble size determination of flotation column froths, Canadian Metall. Quarterly, 25(1), p.23
- Yianatos, J.B., Finch, J.A. and Laplante, A.R. 1987. Cleaning action in column flotation froths, Trans. Inst. Min. & Metall., Section C, 96, p.199
- Yoon, R.H. and Luttrell, G.H. 1994. Microcel column flotation scale-up and plant practice, CMP Proc. 26th Annual Meeting, paper 12

## CONTACT INFORMATION

Email us at [minerals@sgs.com](mailto:minerals@sgs.com)

[WWW.SGS.COM/MINERALS](http://WWW.SGS.COM/MINERALS)

© 2011 SGS. All rights reserved. The information contained herein is provided "as is" and SGS does not warrant that it will be error-free or will meet any particular criteria of performance or quality. Do not quote or refer any information herein without SGS' prior written consent. Any unauthorized alteration, forgery or falsification of the content or appearance of this document is unlawful and offenders may be prosecuted to the fullest extent of the law.